

# PRELIMINARY PLAT BUSHLAND SPRINGS

LOTS 147 THROUGH 413  
AN ADDITION TO THE CITY OF LUBBOCK,  
LUBBOCK COUNTY, TEXAS

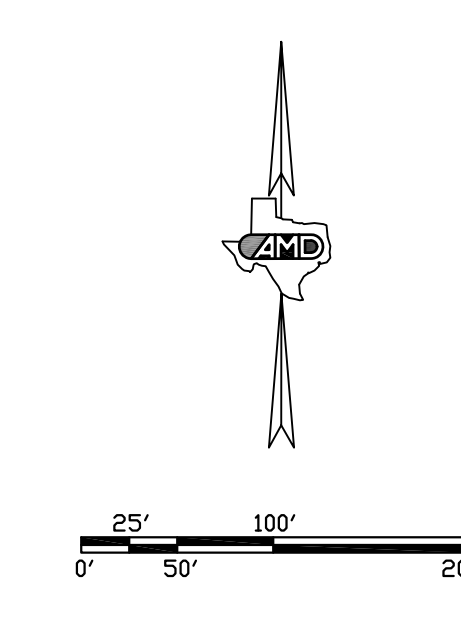

SCALE 1" = 100'  
HEAVY LINES INDICATE PLAT LIMITS.  
ALL STREETS ALLEYS AND INDICATED EASEMENTS ARE HEREIN DEDICATED, UNLESS NOTED OTHERWISE.  
ALL EASEMENTS DESIGNATED BY THIS PLAT SHALL ENTITLED THE CITY OR THE UTILITY COMPANY USING SUCH EASEMENTS TO THE RIGHT TO REMOVE, REPAIR OR REPLACE ANY LINES, PIPES, CONDUITS OR POLES WITHIN SUCH EASEMENTS AS MAY BE DETERMINED BY THE CITY OR UTILITY COMPANY WITHOUT THE CITY OR UTILITY COMPANY BEING RESPONSIBLE OR LIABLE FOR THE REPLACEMENT OF IMPROVEMENTS PAVING OR SURFACING OF THE EASEMENTS NECESSITATED BY SUCH REPAIR OR REPLACEMENT. EASEMENTS DESIGNATED OR INTENDED FOR VEHICULAR PASSAGE, UTILITY AND EMERGENCY OR PEDESTRIAN ACCESS SHALL NOT BE FENCED OR OTHERWISE OBSTRUCTED.  
ALL ELECTRICAL SERVICE WITHIN THE CITY OF LUBBOCK SHALL BE IN ACCORDANCE WITH THE UNDERGROUND UTILITIES POLICY STATEMENT BY THE PLANNING AND ZONING COMMISSION OF THE CITY OF LUBBOCK, TEXAS AND THE PROVISIONS OF SECTION 36.09.095 OF THE LUBBOCK CODE OF ORDINANCES.  
ALL EXISTING OR PROPOSED UTILITY SERVICE TO AND ON TRACTS INDICATED BY THIS PLAT SHALL BE CONTAINED IN THE PUBLIC RIGHT-OF-WAY AND PUBLIC OR PRIVATE UTILITY EASEMENTS INDICATED BY THIS PLAT. SHALL BE WITHIN A PROPER UTILITY EASEMENT GRANTED BY THE OWNER OF SAID PROPERTY BY SEPARATE RECORDED INSTRUMENT PRIOR TO THE PROVISION OF SUCH SERVICE. SUCH SEPARATE EASEMENT COSTS SHALL BE AT THE EXPENSE OF THE PROPERTY OWNER. NO BUILDING PERMIT SHALL BE ISSUED ON ANY SURVEY CERTIFICATE THAT IS NOT IN ACCORDANCE WITH AN APPROVED FINAL PLAT UNLESS AN EXCEPTION IS PROVIDED BY PLANNING AND ZONING COMMISSION POLICY OR BY THE LUBBOCK CODE OF ORDINANCES.  
MINIMUM FLOOR ELEVATION SHALL CONFORM TO THE REQUIREMENTS OF THE LUBBOCK DRAINAGE CRITERIA MANUAL, AS ADOPTED BY ORDINANCE 10002, AS AMENDED, AND SECTION 28.09.131, SECTION 31.04 AND SECTION 30.03.073 OF THE LUBBOCK CODE OF ORDINANCES.  
IN ORDER TO PREVENT DAMAGE TO PUBLIC AND PRIVATE UTILITIES AND TO MINIMIZE AND OR ELIMINATE INTERRUPTION OF UTILITY SERVICES, THE CITY OF LUBBOCK SOLID WASTE SERVICES DEPARTMENT REQUESTS THAT NO UTILITY RISERS, METER BASES, PEDESTALS, ETC., PUBLIC OR PRIVATE, BE PLACED IN THE CHAMFERED CORNERS OF ALLEYWAYS.  
PUBLIC PEDESTRIAN ACCESS EASEMENT IS HEREIN GRANTED FOR PERSON TRAVELING ALONG THE PUBLIC PARKWAY AND NEADING TO ENTER UNIMPROVED PRIVATE PROPERTY FOR THE PURPOSE OF LOADING AND UNLOADING OF VEHICLES. THE EASEMENT IS LIMITED TO THOSE PORTIONS OF THE AS-CONSTRUCTED DRIVEWAYS AND WALK WHICH MAY EXTEND OUTSIDE PUBLIC RIGHT-OF-WAY DATED PRIVATE PROPERTY AND ARE CONSTRUCTED FOR THE CONTINUANCE OF THE ACCESSIBLE WHEELCHAIR ROUTES ACROSS THE BACK OF THE DRIVEWAY. THIS EASEMENT APPLIES TO EXISTING AND ANY FUTURE DRIVE ENTRANCES AS CONSTRUCTED.  
ANY EASEMENTS OR RIGHTS-OF-WAY SHOWN AS TO BE DEDICATED BY SEPARATE INSTRUMENT ARE SHOWN HEREIN FOR INFORMATION PURPOSES ONLY. THIS PLAT DOES NOT DEDICATE SAID EASEMENTS.  
DRE = DRAINAGE EASEMENT  
LPL = LUBBOCK POWER & LIGHT  
OPE = OVERHEAD POWER LINE EASEMENT  
R-DW = RIGHT-OF-WAY  
SDD = STREET DEED DEDICATION  
SPEC = SOUTH PLAINS ELECTRIC COOPERATIVE  
SPS = SOUTHWESTERN PUBLIC SERVICE  
CH = CONTROLLING POINT NUMBER  
UUE = UNDERGROUND UTILITY EASEMENT  
UWE = UNDERGROUND WATER LINE EASEMENT  
CCFN = COUNTY CLERK'S FILE NUMBER  
PMBD = PHYSICAL MONUMENT OF RECORD DIGNITY  
ALL CORNERS MONUMENTED WITH 1/2" IRON ROD WITH CAP MARKED "AMD ENG", UNLESS OTHERWISE SPECIFIED.  
COORDINATES SHOWN HEREIN ARE BASED ON THE TEXAS COORDINATE SYSTEM OF 1983, TEXAS NORTH CENTRAL ZONE. DISTANCES AS SHOWN HEREIN ARE AT SURFACE, IN U.S. FEET.  
THESE PLAT LIMITS CONTAIN 68.03 ACRES OF LAND.  
DESCRIPTION OF THESE PLAT LIMITS ARE ON A SEPARATE DOCUMENT, OF SAME DATE HEREWITH.

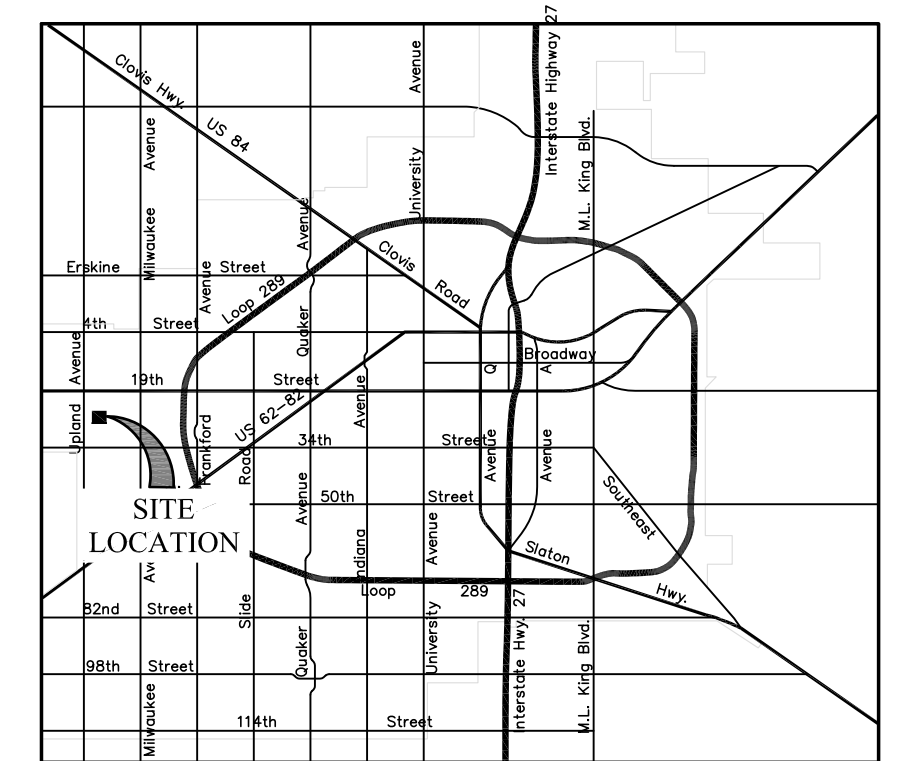

CURVE TABLE					CURVE TABLE					LINE TABLE					LINE TABLE				
CURVE	RADIUS	DELTA	ARC LENGTH	CH CHORD	CURVE	RADIUS	DELTA	ARC LENGTH	CH CHORD	LINE	LENGTH	BEARING	LINE	LENGTH	BEARING				
C1	50.00	30°11'39"	30.71	57°38'18"E	30.23	C32	50.00	24°24'52"	21.30	56°12'57"E	21.14	L39	21.21	S46°50'18"W					
C2	43.00	10°53'26"	8.17	S88°21'27"E	8.16	C33	50.00	10°48'21"	9.40	S87°48'47"E	9.39	L40	21.21	N47°12'08"W					
C3	43.00	11°41'51"	88.78	S89°03'54"E	4.29	C34	45.00	28°26'59"	23.12	S77°24'26"E	22.87	L41	21.21	N46°47'52"E					
C4	43.00	10°53'26"	77.63	N49°55'33"W	67.51	C35	45.00	12°11'45"	9.98	S86°15'31"W	9.96	L42	21.20	N43°09'44"W					
C5	43.00	21°44'43"	16.32	S87°28'37"W	16.29	C36	50.00	5°23'50"	50.52	S77°06'34"W	48.40	L43	21.20	N46°50'18"E					
C6	50.00	30°11'39"	30.71	S74°12'03"W	30.23	C37	50.00	7°24'43"	64.35	N35°04'19"W	60.00	L44	21.20	S88°12'08"E					
C7	50.00	28°33'11"	24.92	N73°55'22"E	24.66	C38	50.00	7°24'43"	64.35	N36°40'04"E	60.00	L45	21.21	N46°50'18"E					
C8	50.00	08°30'08"	0.79	N68°19'33"W	0.79	C39	50.00	5°23'50"	50.52	S77°06'34"W	48.40	L46	14.14	N47°12'08"E					
C9	43.00	10°53'26"	93.95	S84°23'33"W	76.34	C40	45.00	12°11'45"	9.98	S52°39'48"E	9.96	L47	14.14	S46°47'52"W					
C10	43.00	10°53'26"	93.95	S80°47'48"E	76.34	C41	45.00	29°26'59"	23.12	S72°28'53"E	22.87	L48	21.20	N43°09'44"W					
C11	50.00	04°52'59"	4.29	N59°03'54"E	4.29	C42	45.00	14°18'32"	23.12	S77°04'38"W	22.87	L49	21.20	N46°50'18"E					
C12	50.00	30°11'39"	26.41	N76°39'43"E	26.11	C43	45.00	12°11'45"	9.98	S86°15'31"W	9.96	L50	14.14	S47°12'08"E					
C13	50.00	30°11'39"	30.71	S74°12'03"W	30.23	C44	50.00	30°11'39"	30.71	S77°06'34"W	48.40	L51	14.14	N46°50'18"E					
C14	43.00	21°44'43"	16.32	S83°52'52"E	16.22	C45	50.00	7°24'43"	64.35	N35°04'19"W	60.00	L52	21.21	N47°12'08"E					
C15	43.00	10°53'26"	77.63	N85°21'18"E	67.51	C46	50.00	7°24'43"	64.35	N36°40'04"E	60.00	L53	27.00	N88°12'08"E					
C16	43.00	11°41'51"	88.78	N85°21'18"E	72.44	C47	50.00	10°53'26"	88.78	S77°06'34"W	48.40	L54	21.20	N43°09'44"W					
C17	43.00	10°53'26"	8.17	S86°02'37"W	8.16	C48	45.00	12°11'45"	9.98	S52°39'48"E	9.96	L55	21.20	N46°50'18"E					
C18	50.00	30°11'39"	30.71	S74°12'03"W	30.23	C49	45.00	28°26'59"	23.12	S77°24'26"E	22.87	L56	22.00	N47°12'08"E					
C19	50.00	30°11'39"	30.71	N70°36'18"W	30.23	C50	50.00	30°11'39"	30.71	N72°12'03"E	30.23	L57	14.14	N46°47'52"E					
C20	43.00	21°44'43"	16.32	S82°09'33"W	16.22	C51	43.00	28°26'59"	23.12	N68°12'08"E	17.43	L58	14.14	N43°09'44"W					
C21	43.00	10°53'26"	77.63	S86°14'36"W	66.30	C52	43.00	10°53'26"	77.63	S49°05'24"E	66.74	L59	14.14	S46°50'18"E					
C22	43.00	21°44'43"	16.32	S87°28'37"W	16.29	C53	43.00	10°53'26"	77.63	N68°12'08"E	17.43	L60	21.20	N43°09'44"W					
C23	43.00	21°44'43"	16.32	N70°36'18"W	16.22	C54	43.00	28°26'59"	23.12	N68°12'08"E	17.43	L61	21.20	N46°50'18"E					
C24	50.00	27°36'31"	24.09	N70°24'29"E	23.86	C55	50.00	30°11'39"	30.71	N70°36'18"W	30.23	L62	14.14	S47°12'08"E					
C25	50.00	07°45'08"	0.79	N68°19'33"W	0.79	C56	50.00	30°11'39"	30.71	N72°12'03"E	30.23	L63	14.14	S47°12'08"E					
C26	50.00	12°50'39"	10.55	S85°45'05"W	10.53	C57	43.00	28°26'59"	23.12	N68°12'08"E	17.43	L64	21.21	N46°47'52"E					
C27	50.00	23°06'50"	20.15	S86°09'15"W	20.02	C58	43.00	10°53'26"	77.63	S49°06'24"E	66.74	L65	21.33	S46°47'52"E					
C28	43.00	30°11'39"	33.31	S76°48'07"W	32.49	C59	43.00	10°53'26"	77.63	S52°42'09"W	66.74	L66	13.87	N87°19'24"W					
C29	43.00	80°47'59"	60.83	N38°38'57"W	55.23	C60	43.00	28°26'59"	23.12	N70°36'18"W	17.43	L67	18.86	N87°11'09"W					
C30	43.00	82°18'54"	61.37	N42°53'20"E	56.59	C61	50.00	30°11'39"	30.71	N70°36'18"W	30.23	L68	21.20	N47°12'08"E					
C31	43.00	42°52'44"	32.18	S74°26'51"E	31.43							L69	21.21	N46°47'52"E					